



We reach for the sky.

YOUR WAY  
— TO THE —  
**TOP**  
REALISE THE POTENTIAL



**ALP-Personnel-Lifts**

[www.boecker-group.com](http://www.boecker-group.com)

# ALP-Lifts by Böcker

## More modern than ever!

For more than 30 years, Böcker has been known as the producer of personnel and material lifts with the brand name ALP-lift. Today, the proven concept of extremely compact, light machines with payloads and lifting heights above average is more modern than ever. Use the ALP-lifts for the carriage of passengers for your assembly work and benefit from the advantages of the lifts.

### Efficiency

- ✓ Lightweight aluminium design ensures minimum dead weight and high payloads
- ✓ Compact dimensions with flexible working heights

### Speed

- ✓ Safely and quickly ready for use thanks to short setting-up time
- ✓ Easy transport thanks to compact dimensions

### Comfort

- ✓ Easy to manoeuvre, therefore can be used everywhere
- ✓ Extendable to the desired height thanks to the precise control with the footswitch

### Versatility

- ✓ Almost unlimited possibilities of indoor and outdoor use
- ✓ Wide range of accessories for even more variability

### Quality

- ✓ Made in Germany
- ✓ Use of metric materials only



Small and compact, can be used in any place



PHC-Lift – perfect for the use in sports halls



## Perfect for assembly, repair and maintenance

The ALP-personnel-lifts are practically irreplaceable for assembly or repair works, especially in closed rooms with a high ceiling. Whether for assembly, repair, maintenance or cleaning, with the ALP-lifts by Böcker you can reach the optimum working height at any time. On site, the machines are immediately ready for use and offer maximum efficiency and a high working speed thanks to the user-friendly operation.

### Wide product range

- ✓ Powerful PH lift
- ✓ Compact PHC lifts
- ✓ Practical PHC-HI lifts with integrated lift truck

### Enormous performance

- ✓ Maximum working height up to 14 m
- ✓ Payloads up to 140 kg ensure the transport of tools

### Simple operation

- ✓ Precise control with footswitch
- ✓ 230 volt drive

### Comfortable transport

- ✓ Integrated loading unit facilitates loading into the van or onto the trailer
- ✓ Fits through small halls, standard doors or lifts



UNI-Lift PHC 1000 EU – the solution for cinemas, theaters, lecture halls etc.

Industrial lifts without outriggers for the use in narrow halls

# Standard Equipment

All ALP-personnel-lifts by Böcker come with extensive standard equipment which guarantees a safe and user-friendly operation.



**1** Available with hand or foot control

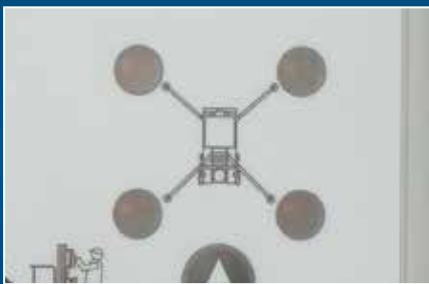

**2** Outrigger control unit with warning light



**3** Extra control unit below



**4** Spirit level for correct and safe positioning





# Accessories

The wide range of accessories for all ALP-personnel-lifts by Böcker fulfills nearly any wish. We also manufacture special models.



**5** Loading unit with height adjustable wheels

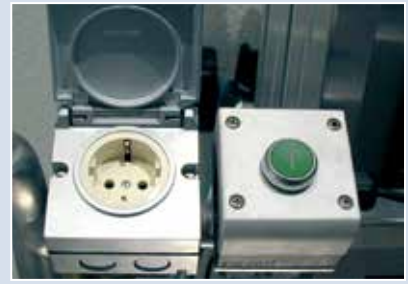

Power supply in work basket



**6** 1,5 kw power unit



Tool box



Rotating (axis) wheels for 360° positioning



**7** Outrigger brackets facilitate the transport



Special wheels available for operation in different locations



Crane lifting points for safe transport



**8** Forklift pocket for a problem-free transport

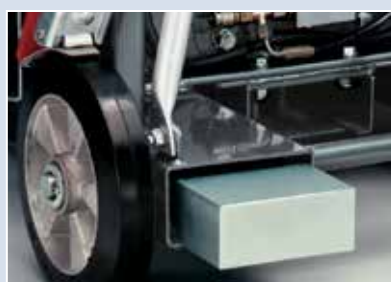

Ballast weights for use with shorter outriggers



Counter weights for outriggers



**9** Wheels with stabilizing brakes



Electrically extendable work basket



Protective cover

# Technical Data

## Standard lift

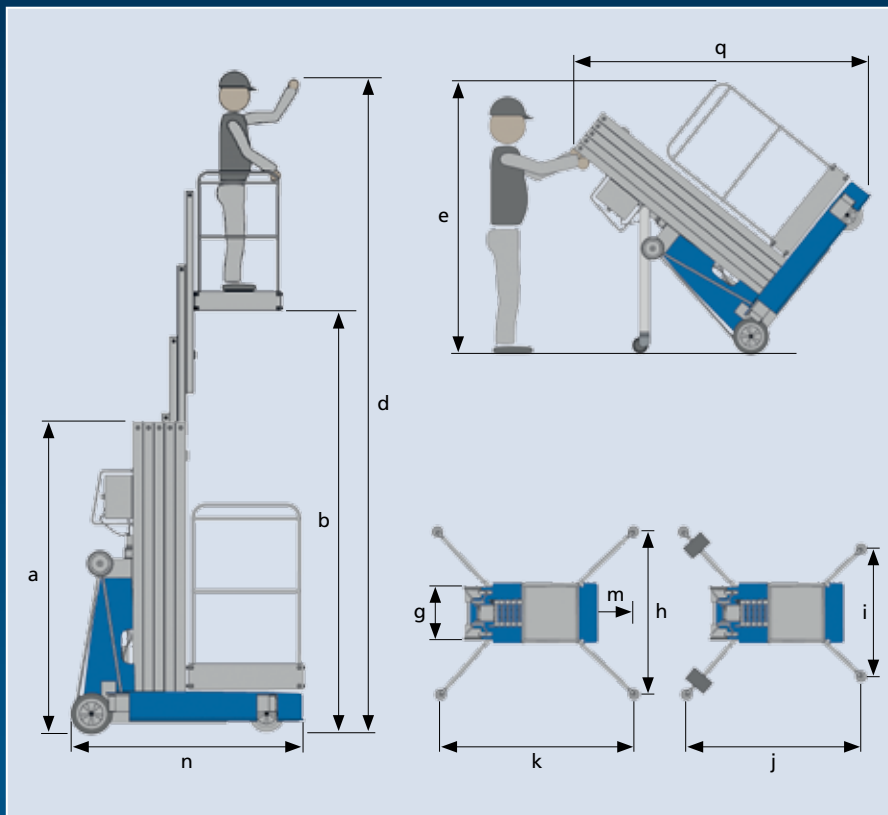

## Industrial lift

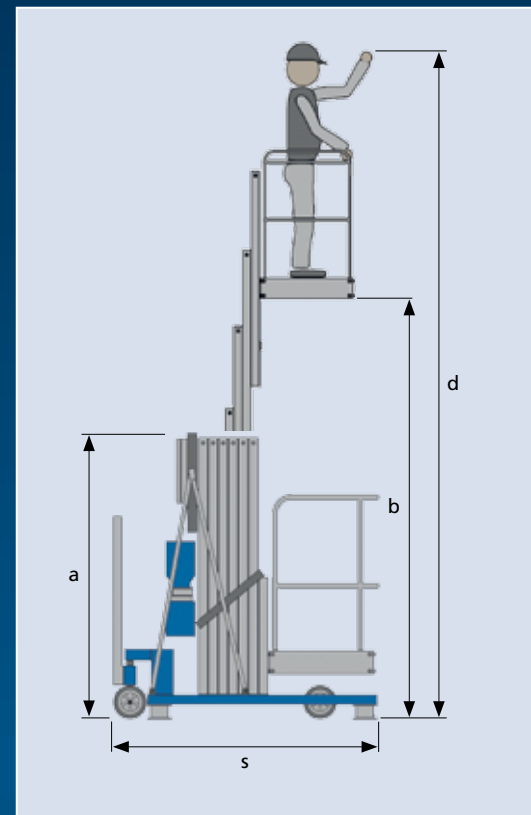

## Standard lift

Model		PHC 650	PHC 800	PHC 940	PHC 1100	PHC 1200	PH 1300	PH 1400
Working height [m]	d	6.50	8.00	9.45	10.85	12.00	12.75	14.00
Platform height [m]	b	4.50	6.00	7.45	8.85	10.00	10.75	12.00
Payload [kg]		140	140	140	140	135	135	115
<b>Dimensions</b>								
Height [m]	a	1.98	1.98	1.98	1.98	1.98	2.30	2.77
Width [m]	g	0.77	0.77	0.77	0.77	0.77	0.77	0.77
Length [m]	n	1.26	1.32	1.38	1.44	1.44	1.44	1.44
Length tipped [m]	q	–	–	–	–	–	2.40	2.85
Height tipped [m]	e	–	–	–	–	–	1.98	1.95
Outrigger footprint (inside) [m]	h x k	1.25 x 1.26	1.41 x 1.39	1.53 x 1.50	1.74 x 1.78	2.04 x 2.05	2.18 x 2.17	2.29 x 2.25
Outrigger footprint (inside) with ballast weights [m]	h x k	–	1.25 x 1.26	1.25 x 1.26	1.41 x 1.49	1.61 x 1.67	1.81 x 1.85	2.04 x 2.05
Outrigger footprint (outside) [m]	h x k	2.04 x 1.95	2.43 x 2.28	2.73 x 2.55	3.24 x 3.10	3.67 x 3.47	3.67 x 3.47	3.90 x 3.67
Outrigger footprint (outside) in front of walls [m]	i x j	1.25 x 1.62	1.41 x 1.86	1.53 x 2.05	1.74 x 2.46	2.04 x 2.79	2.18 x 2.85	2.29 x 3.00
Distance from wall [cm]	m	9	10	9	21	34	40	45
Dead weight without ballast weights [kg]		250	280	300	330	345	394	430
Dead weight with ballast weights [kg]		294	354	384	414	429	478	514
Extension speed approx. [sec.]		28	26	21	26	26	35	40

We reserve the right to make changes to the design, weight and dimensions of equipments.

# UNI-lift

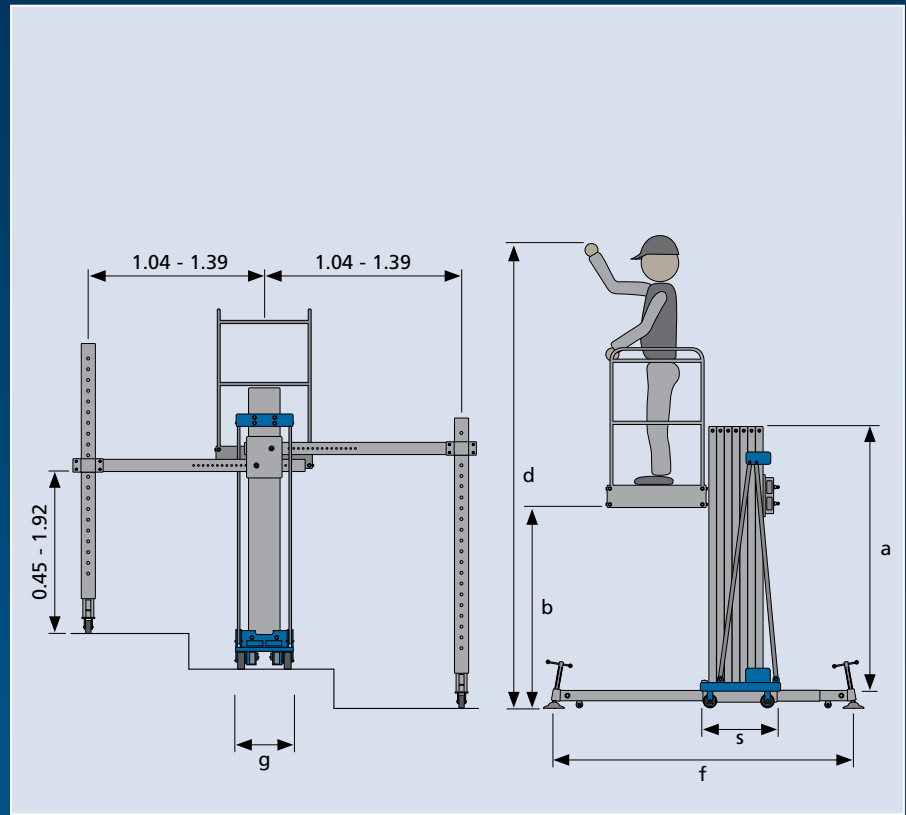
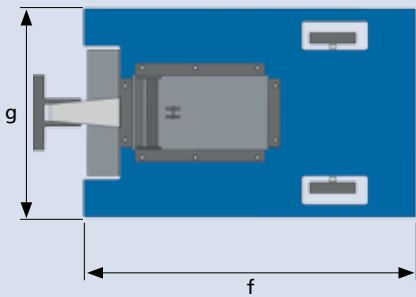

## Industrial lift

Model		PHC-HI 800	PHC-HI 940	PHC-HI 1100	PHC 1000 EU
Working height [m]	d	8.00	9.40	10.80	10.50
Platform height [m]	b	6.00	7.40	8.80	8.5
Payload [kg]		140	140	140	140
<b>Dimensions</b>					
Height [m]	a	1.98	1.98	1.98	1.99
Width [m]	g	0.79	0.79	0.89	0.41
Length [m]	f/s	1.37/1.61	1.37/1.61	1.43/1.67	2.63/0.59
Length tipped [m]		–	–	–	–
Height tipped [m]		–	–	–	–
Oustrigger footprint (inside) [m]	g x s	0.79 x 1.61	0.79 x 1.61	0.89 x 1.67	variable
Oustrigger footprint (inside) with ballast weights [m]		–	–	–	–
Oustrigger footprint (outside) [m]		–	–	–	–
Oustrigger footprint (outside) in front of walls [m]		–	–	–	–
Distance from wall [cm]		0	0	0	0.45
Dead weight without ballast weights [kg]		678	715	825	215
Dead weight with ballast weights [kg]		–	–	–	–
Extension speed approx. [sec.]		26	21	26	26

We reserve the right to make changes to the design, weight and dimensions of equipments.

## UNI-lift

**Böcker – made in  
GERMANY**



**DENSEST  
SERVICE-NETWORK  
IN EUROPE**

**Böcker Belgium NV**

Boomsesteenweg 101 · B-2630 Aartselaar  
Fon +32 (0) 3 / 45 76 241  
Fax +32 (0) 3 / 45 76 242  
Mail [belgium@boecker-group.com](mailto:belgium@boecker-group.com)

**Böcker France SAS**

Zac du TEC · F-30320 Marguerittes  
Fon +33 (0) 4 6620 9364  
Fax +33 (0) 4 6620 9926  
Mail [france@boecker-group.com](mailto:france@boecker-group.com)

**Böcker Italia srl**

Corso Porta Nuova 11 · I-37122 Verona (VR)  
Fon +39 045 / 87 80 399  
Fax +39 045 / 87 80 420  
Mail [italia@boecker-group.com](mailto:italia@boecker-group.com)

**Böcker Nederland B.V.**

De Geerden 22 · NL-5334 LE Velddriel  
Fon +31 (0) 418 / 571 444  
Fax +31 (0) 418 / 635 222  
Mail [nederland@boecker-group.com](mailto:nederland@boecker-group.com)

**Böcker Schweiz AG**

Striegelstraße 1 · CH-4665 Oftringen  
Fon +41 (0) 62 / 797 62 62  
Fax +41 (0) 62 / 797 62 68  
Mail [schweiz@boecker-group.com](mailto:schweiz@boecker-group.com)

**Böcker Satış Ofisi Türkiye**

TR-34315 Denizköşkler Avcılar / İstanbul  
Fon +90 (542) 618 06 96  
Fax +49 (0) 2389 / 7989-9134  
Mail [tuerkiye@boecker-group.com](mailto:tuerkiye@boecker-group.com)

**Branch office north**

Farmers Ring 8 · D-25337 Koelln-Reisiek  
Fon +49 (0) 4121 / 57 10 00  
Fax +49 (0) 4121 / 57 10 01  
Mail [nl nord@boecker-group.com](mailto:nl nord@boecker-group.com)

**Branch office east**

Freiheit 20–21 · D-13597 Berlin-Spandau  
Fon +49 (0) 30 / 3 39 39 04-0  
Fax +49 (0) 30 / 3 39 39 04-29  
Mail [nl east@boecker-group.com](mailto:nl east@boecker-group.com)

**Branch office middle**

Kasseler Str. 62 · D-34277 Fuldabrück  
Fon +49 (0) 561 / 5 85 46 73  
Fax +49 (0) 561 / 5 85 46 74  
Mail [nl mitte@boecker-group.com](mailto:nl mitte@boecker-group.com)

**Branch office south-west**

Bussardstr. 16 · D-68753 Waghäusel  
Fon +49 (0) 72 54 / 9 58 85-0  
Fax +49 (0) 72 54 / 9 58 85-29  
Mail [nl suedwest@boecker-group.com](mailto:nl suedwest@boecker-group.com)

**Branch office south**

Kirchweg 4 · D-82239 Alling  
Fon +49 (0) 81 41 / 888 601  
Fax +49 (0) 81 41 / 53 72 707  
Mail [nl sued@boecker-group.com](mailto:nl sued@boecker-group.com)



Wir sind die Höhe.

**Böcker Maschinenwerke GmbH**

Lippestraße 69–73 · D-59368 Werne  
Fon +49 (0) 23 89 / 79 89-0  
Fax +49 (0) 23 89 / 79 89-9000  
Mail [info@boecker-group.com](mailto:info@boecker-group.com)